



January 2024

Soucy Baron |



## New Electric Vehicle Designs Benefit from Rubber Component Expertise

Electric vehicles and machinery are transforming multiple industries, including agriculture. Many manufacturers are just now introducing their first-generation electric versions of different types of machinery such as tractors and loaders. For the agriculture industry, electric machinery offers the benefits of reduced fuel and maintenance costs and decreases in CO2 emissions.

Engineers are facing never-before-seen design requirements for these groundbreaking vehicles. Successfully merging the benefits of electric motors with the functionality required of each vehicle is an opportunity to set industry standards with outstanding design.

Custom rubber components have an essential role to play in optimized designs of new electric vehicles (EVs). By collaborating with rubber component experts, original equipment manufacturers can ensure that their new designs take advantage of efficiency, performance and durability gains through strategic rubber component development.

Examples of rubber components typically found in agricultural machinery:

> Seals

> Gaskets

> Bump stops

> Air intake and exhaust hoses

> Suspension hangers

**How does a custom rubber solution project work? Read on to find out.**

## What is the challenge?

For end users, the decision about whether or not to invest in EVs is complex. Minimizing fuel costs and supporting sustainability goals are good reasons to switch to electric power, but EVs must also be reliable and not cause any unscheduled downtime. The agriculture industry requires dependable, high-performance vehicles and equipment.

For equipment manufacturers, EVs present many design challenges. Although from the outside an electric vehicle may resemble one with a combustion engine, under the hood the differences are vast. The top-level components and powertrain system are completely different: instead of a gas tank, fuel pump, and fuel lines, there's a "motor battery" (not

the same as the auxiliary battery used to power accessories), the electric motor, plus a converter, charger, and different transmission.

One key difference in electric motors is torque. Since rubber helps with vibration and shock absorption an OEM may want to specify rubber components when designing an engine mount, for example. The correct rubber formulation will absorb vibration without compressing to the point of affecting alignment. However, without rubber expertise, the vehicle manufacturer may not know where to begin. A custom-engineered rubber solutions provider can offer the expertise needed.

## What level of performance is needed?

To determine how rubber components could be advantageous in a new EV engine mount design, for example, technical experts will start by asking specific questions such as:

- > What's the weight of the motor?
- > What's the weight of the battery?
- > Where are the components going to be located?
- > What frequency range needs to be absorbed?
- > What amount of torque or force will the engine exert initially?



The engineered rubber solutions team would also have questions about environmental factors. For example, if the engine mount is for agricultural machinery, then it needs to be resistant to dirt, mud, oils, pesticides, and other hazards.

Performance requirements will inform decisions about the best formula, mold, and bonding to use to develop the best components. Manufacturing constraints, including the estimated annual usage of the part, would also need to be provided.

The earlier the rubber solutions team is involved in the process, the better. With fewer restrictions in place, more options will be available. If multiple constraints are already in place, rubber component development can still be done, but it may not be able to be created as cost-effectively as a design done earlier in an earlier stage of development.

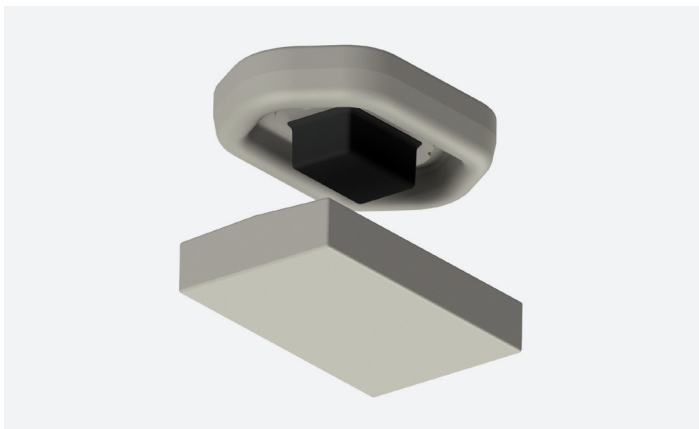

## Will a rubber solution work?

After receiving the necessary information and schematics, the rubber solutions engineers will create a design and then run finite element analysis (FEA) simulations to understand how the component will behave. Based on the simulation results, the team will make necessary adjustments before making the prototype.

This simulation step saves time, and results in a better prototype. The vehicle manufacturer can then test the prototype and either move to production or have the design refined, re-prototyped and re-tested to be sure that the rubber components are beneficial to the EV.

## How do you start a project?

As soon as you start planning to develop a new electric vehicle that may require rubber components to optimize performance and durability, contact a rubber solutions expert. It usually only takes one phone call to confirm that we can meet your needs. In the earliest design phases, we can help firm up your ideas and provide fast concept validation with 3D-printed prototypes. We'll work with you every step of the way, defining requirements, developing formulas as needed, running physical performance tests, and ensuring compliance. As an ISO certified company, our quality control is rigorous.

Soucy Baron develops engineered, high-performance customized rubber products that meet challenging technical requirements for EVs used in a wide variety of industries. We have the facilities, technology and experience to simulate, design, formulate and produce molded elastomeric components that increase durability and enhance the performance of EVs. Noise, vibration and harshness (NVH) is one of our specialties along with rubber-to-metal bonding. With our technical dominance in materials engineering and experience working directly with OEMs, we provide quality, high-performance compounds for your component needs.

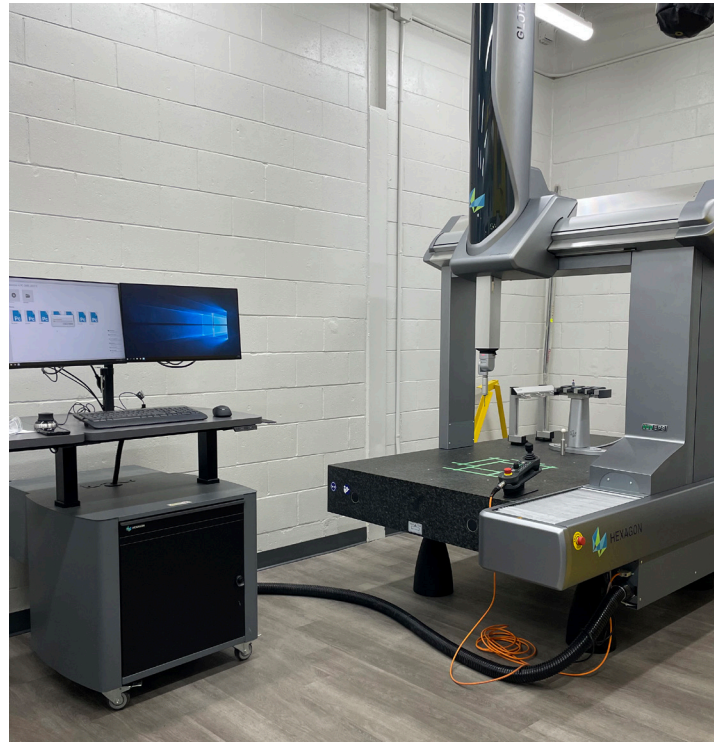

**To learn more about how to incorporate custom rubber solutions into the design of EVs, [contact us.](#)**